

型番	$\phi D1$	T1min	G1min	X	$\phi D2$	T2min	G2min	Y	適合規格*
T952-635	9.62	0.60	8.00	8.0	6.45	0.50	6.00	6.0	JIS B 8607
T1270-635	12.81	0.70	9.00	8.0	6.45	0.50	6.00	9.0	JIS B 8607
T1270-8M	12.81	0.70	9.00	8.0	8.10	0.50	7.00	9.0	JIS B 8607
T1270-952	12.81	0.70	9.00	8.0	9.62	0.60	8.00	9.0	JIS H 3401, JIS B 8607
T1588-635	16.00	0.80	11.00	10.0	6.45	0.50	6.00	12.0	JIS B 8607
T1588-952	16.00	0.80	11.00	10.0	9.62	0.60	8.00	12.0	JIS B 8607
T1588-1270	16.00	0.80	11.00	10.0	12.81	0.70	9.00	12.0	JIS H 3401, JIS B 8607
T1905-635	19.19	0.80	15.00	14.5	6.45	0.50	6.00	15.0	
T1905-952	19.19	0.80	15.00	14.5	9.62	0.60	8.00	15.0	JIS B 8607
T1905-1270	19.19	0.80	15.00	14.5	12.81	0.70	9.00	15.0	JIS H 3401, JIS B 8607
T1905-1588	19.19	0.80	15.00	14.5	16.00	0.80	11.00	15.0	JIS H 3401, JIS B 8607
T2222-952	22.36	0.90	17.00	16.0	9.62	0.60	8.00	16.0	
T2222-1270	22.36	0.90	17.00	16.0	12.81	0.70	9.00	16.0	JIS H 3401, JIS B 8607
T2222-1588	22.36	0.90	17.00	16.0	16.00	0.80	11.00	16.0	JIS H 3401, JIS B 8607
T2222-1905	22.36	0.90	17.00	16.0	19.19	0.80	15.00	16.0	JIS H 3401, JIS B 8607
T2540-1270	25.56	0.95	19.00	18.0	12.81	0.70	9.00	18.0	JIS B 8607
T2540-1588	25.56	0.95	19.00	18.0	16.00	0.80	11.00	18.0	JIS B 8607
T2540-1905	25.56	0.95	19.00	18.0	19.19	0.80	15.00	18.0	JIS B 8607
T2540-2222	25.56	0.95	19.00	18.0	22.36	0.90	17.00	18.0	JIS B 8607
T2858-1270	28.75	1.00	21.00	20.0	12.81	0.70	9.00	20.0	
T2858-1588	28.75	1.00	21.00	20.0	16.00	0.80	11.00	20.0	JIS H 3401
T2858-1905	28.75	1.00	21.00	20.0	19.19	0.80	15.00	20.0	JIS H 3401
T2858-2222	28.75	1.00	21.00	20.0	22.36	0.90	17.00	20.0	JIS H 3401

* JIS B 8607 の適合JISマーク刻印は無し。

						INABA DENKO 因幡電機産業株式会社 INABA DENKI SANGYO CO.,LTD. 生産事業部 MANUFACTURING DIVISION	設計 DESIGNED	製図 DRAWN	検図 CHECKED	承認 APPROVED	品名 NAME	異径チーズ (T952-635~T2858-2222) T
		C1220T					金田	金田	金田	龍田		
番号 NO.	部品名 PART'S NAME	材質 MATERIALS	色調 COLOR	数量 QUANTITY	備考 REMARKS		02.06.01	02.06.01	02.06.01	02.06.01	第三角法 3RD ANGLE PROJECTION	

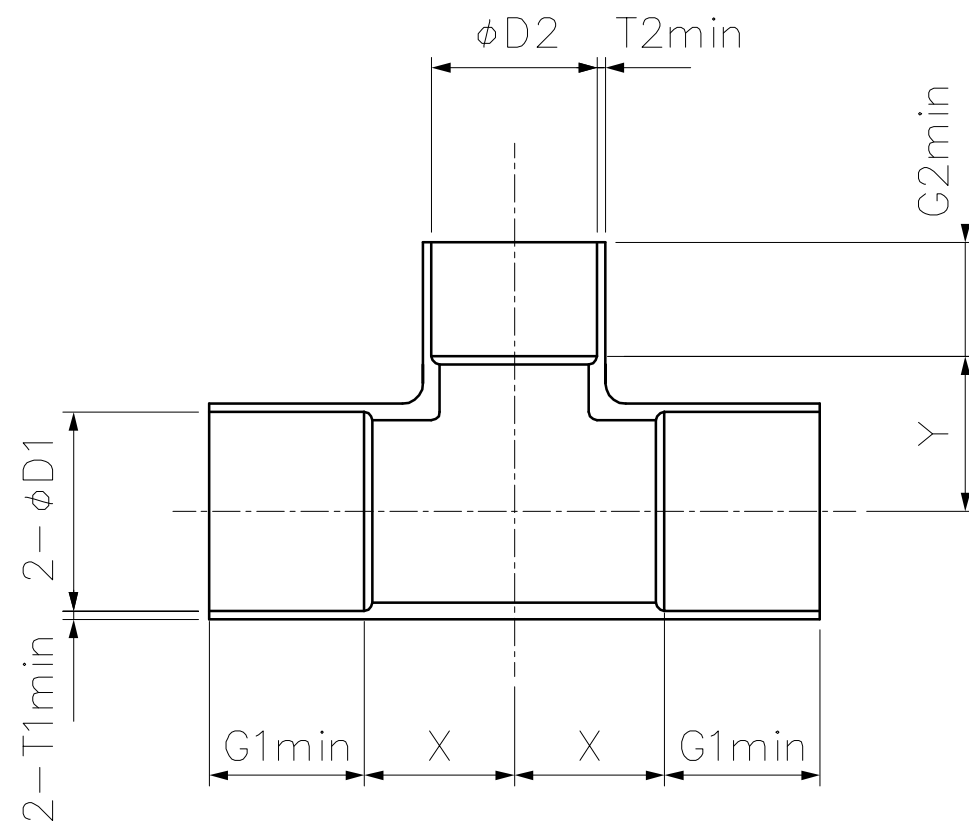

型番	$\phi D1$	T1min	G1min	X	$\phi D2$	T2min	G2min	Y	適合規格*
T2858-2540	28.75	1.00	21.00	20.0	25.56	0.95	19.00	20.0	
T3175-1588	31.93	1.05	22.00	21.0	16.00	0.80	11.00	22.0	
T3175-1905	31.93	1.05	22.00	21.0	19.19	0.80	15.00	22.0	JIS B 8607
T3175-2540	31.93	1.05	22.00	21.0	25.56	0.95	19.00	22.0	JIS B 8607
T3175-2858	31.93	1.05	22.00	21.0	28.75	1.00	21.00	22.0	
T3492-1588	35.11	1.20	24.00	14.0	16.00	0.80	11.00	23.0	JIS H 3401
T3492-2222	35.11	1.20	24.00	16.0	22.36	0.90	17.00	23.0	JIS H 3401
T3492-2540	35.11	1.20	24.00	18.0	25.56	0.95	19.00	23.0	
T3492-2858	35.11	1.20	24.00	20.0	28.75	1.00	21.00	23.0	JIS H 3401
T3810-1905	38.31	1.25	26.00	25.0	19.19	0.80	15.00	25.0	JIS B 8607
T3810-2540	38.31	1.25	26.00	25.0	25.56	0.95	19.00	25.0	JIS B 8607
T3810-2858	38.31	1.25	26.00	25.0	28.75	1.00	21.00	25.0	
T3810-3175	38.31	1.25	26.00	25.0	31.93	1.05	22.00	25.0	JIS B 8607
T4128-1588	41.50	1.30	27.00	15.0	16.00	0.80	11.00	26.5	JIS H 3401
T4128-2222	41.50	1.30	27.00	18.0	22.36	0.90	17.00	26.5	JIS H 3401
T4128-2858	41.50	1.30	27.00	21.0	28.75	1.00	21.00	26.5	JIS H 3401
T4128-3492	41.50	1.30	27.00	24.0	35.11	1.20	24.00	26.5	JIS H 3401
T5080-3175	51.03	1.40	31.00	21.0	31.93	1.05	22.00	30.0	
T5398-1588	54.22	1.50	33.00	20.0	16.00	0.80	11.00	33.5	JIS H 3401
T5398-2222	54.22	1.50	33.00	23.0	22.36	0.90	17.00	33.5	JIS H 3401
T5398-2858	54.22	1.50	33.00	27.0	28.75	1.00	21.00	33.5	JIS H 3401
T5398-3492	54.22	1.50	33.00	29.0	35.11	1.20	24.00	33.5	JIS H 3401
T5398-4128	54.22	1.50	33.00	31.0	41.50	1.30	27.00	33.5	JIS H 3401

* JIS B 8607 の適合JISマーク刻印は無し。

						INABA DENKO 因幡電機産業株式会社 INABA DENKI SANGYO CO.,LTD. 生産事業部 MANUFACTURING DIVISION	設計 DESIGNED	製図 DRAWN	検図 CHECKED	承認 APPROVED	品名 NAME	異径チーズ (T2858-2540~T5398-4128) T
							金田 02.06.01	金田 02.06.01	金田 02.06.01	龍田 02.06.01		
番号 NO.	部品名 PART'S NAME	材質 MATERIALS	色調 COLOR	数量 QUANTITY	備考 REMARKS		尺度 SCALE	F/	第三角法 3RD ANGLE PROJECTION	図番 DRAWING NO.	P-0206-DT008-1	